

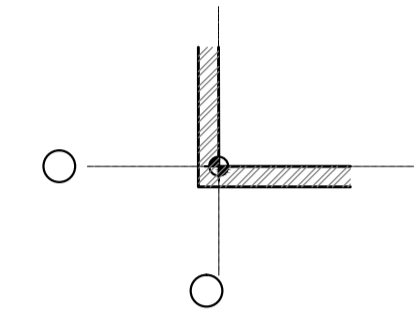

SITE AREA – 20 503.6 m²
(5.067 Acres)



POSITION OF CO-ORDINATES
(grid line intersection)

1. ALL DIMENSIONS ARE TO GRID LINES.
2. SETTING OUT IS TO BE VERIFIED BY FIGURED DIMENSIONS IN ADDITION TO COORDINATES.

SCHEDULE OF COORDINATES

UNITS 3-6		
11	182756.867 N	355459.502 E
12	182651.154 N	355412.597 E
13	182670.658 N	355368.640 E
14	182776.370 N	355415.544 E
24	182667.794 N	355367.369 E
25	182648.158 N	355411.268 E
26	182649.722 N	355415.824 E
27	182755.413 N	355462.777 E
28	182759.799 N	355460.803 E
29	182779.430 N	355416.901 E

SCHEDULE OF COORDINATES
UNIT 1

1	182790.807 N	355384.113 E
2	182739.702 N	355361.437 E
3	182758.974 N	355318.001 E
4	182810.080 N	355340.676 E
15	182793.543 N	355385.327 E
16	182812.950 N	355341.949 E
17	182823.812 N	355309.726 E
18	182772.718 N	355287.025 E

SCHEDULE OF COORDINATES
BOUNDARY

30	182826.778 N	355311.042 E
31	182770.461 N	355286.022 E
32	182763.881 N	355283.099 E
33	182714.901 N	355261.339 E
34	182700.952 N	355292.718 E
35	182646.711 N	355414.496 E
36	182758.337 N	355464.079 E

SCHEDULE OF COORDINATES
UNIT 2

5	182728.605 N	355356.514 E
6	182684.725 N	355337.044 E
7	182702.144 N	355297.784 E
8	182708.575 N	355300.200 E
9	182711.483 N	355293.646 E
10	182749.094 N	355310.334 E
19	182761.624 N	355282.096 E
20	182724.020 N	355265.390 E
21	182702.318 N	355289.580 E
22	182699.261 N	355296.505 E
23	182681.841 N	355335.765 E

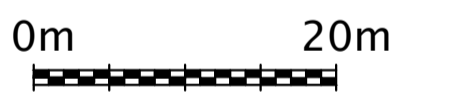

- REV:
- D 16.03.26 Units 1 and 2 moved eastwards by 400mm. Unit 2 yard access width increased to suit.
 - C 19.02.26 Updated.
 - B 20.08.25 Updated.
 - A 28.07.25 Unit 1 yard car spaces repositioned.

PROJECT
Plot 5, Central Park
Palmer Avenue, Avonmouth
Bristol BS35 4GH

DRAWING
Proposed Site Setting Out

SCALE PAPER SIZE DATE DRAWN BY
1:500 A1 10.09.25

DRAWING N° REVISION
041.104.05 SOP D

CAD REF. 041.104.05 SOP D proposed site setting out.dwg

www.ke-architecture.com
studio@ke-architecture.com
Unit 18D, Chiltem Court
Asheridge Road
Chesham, HPS 2PX
t 01494 776042

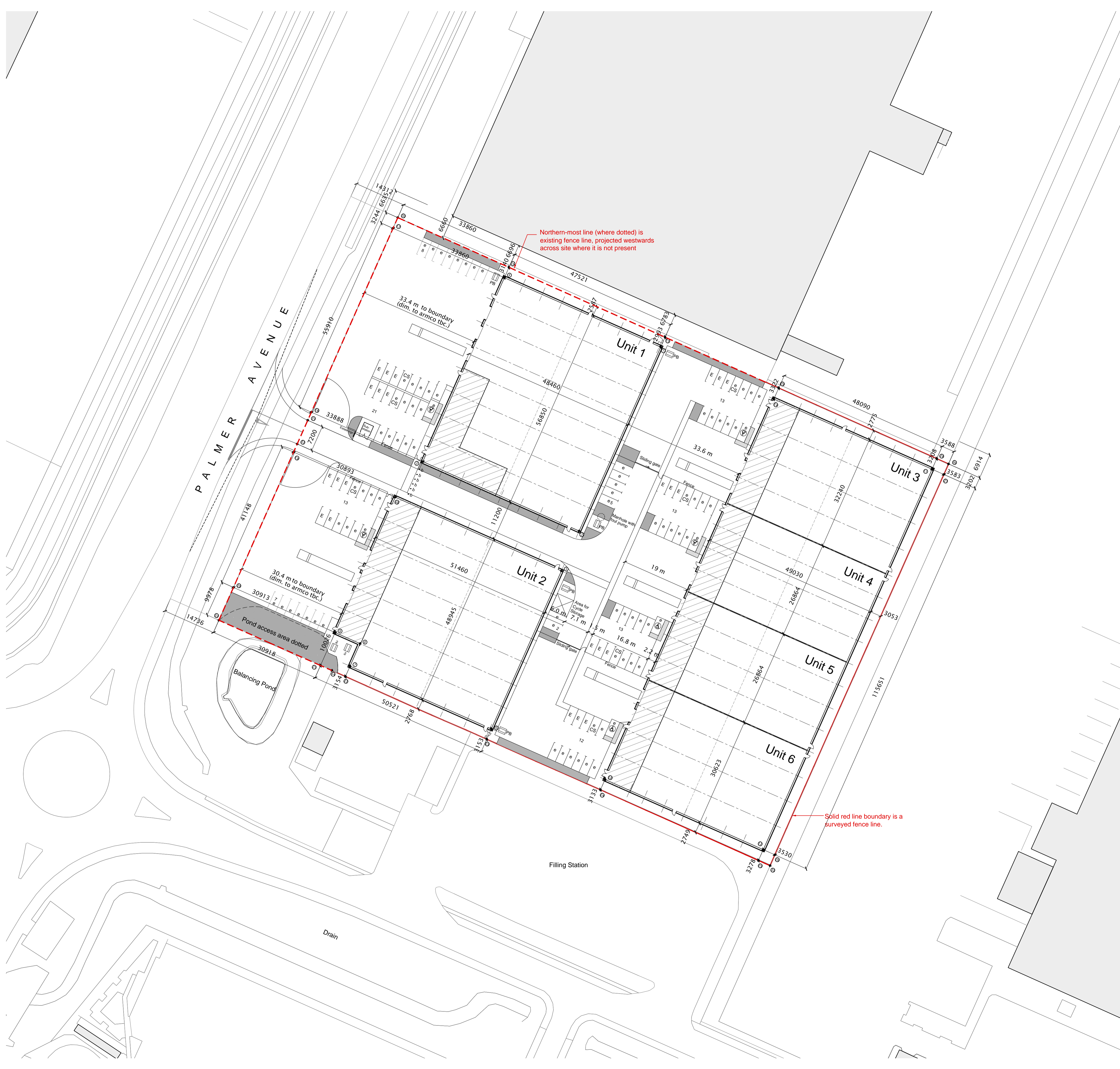

Northern-most line (where dotted) is existing fence line, projected westwards across site where it is not present

Solid red line boundary is a surveyed fence line.